

- Bandwidth up to 24 Gbps
- Non-blocking architecture
- L3 switches
- Passive cooling
- Support for Multicast (IGMP Snooping, MVR)
- Advanced security functions (L2-L4 ACL, IP Source Guard, Dynamic ARP Inspection, etc.)

MES3508, MES3508P and MES3510P industrial switches manufactured by ELTEX are designed to organize secure fault-tolerant networks on sites with high requirements to temperature, vibrations and mechanical impact.

The switches have ports of 10/100/1000BASE-T with PoE/PoE+¹ technology support and Combo ports of 10/100/1000BASE-T/1000BASE-X/100BASE-FX for optional connection of an optic-fiber cable.



Technical features

	MES3508	MES3508P	MES3510P
Interfaces			
10/100/1000BASE-T (RJ-45)	8	—	—
10/100/1000BASE-T PoE/PoE+ (RJ-45)	—	8	8
100BASE-FX/1000BASE-X (SFP)	—	—	4
10/100/1000BASE-T/100BASE-FX/1000BASE-X (RJ-45/SFP) Combo	2	2	—
Console port RS-232 (RJ-45)		1	
Performance			
Bandwidth	20 Gbps	20 Gbps	24 Gbps
Throughput for 64 bytes ²	14 MPPS	14 MPPS	17.8 MPPS
Buffer memory		1.5 MB	
RAM (DDR3)		512 MB	
ROM (RAW NAND)		512 MB	
MAC table		16384	
ARP table ³		4023	
VLAN table		4094	
L2 Multicast groups		4091	
SQinQ rules		3006 (ingress/egress)	
ACL rules		3006	
L3 IPv4 Unicast routes ⁴		12866	
L3 IPv6 Unicast routes ⁴		3222	
L3 IPv4 Multicast routes (IGMP Proxy, PIM) ⁴		3876	
L3 IPv6 Multicast routes (IGMP Proxy, PIM) ⁴		1006	

¹ Excluding MES3508.

² Values are given for 1-way transmission.

³ For each host in the ARP table, an entry is created in the routing table.

⁴ IPv4/IPv6 Unicast/Multicast share hardware resources.

Technical features (continued)

	MES3508	MES3508P	MES3510P
VRRP routers		255	
Maximum size of ECMP groups		8	
VRF		16 (including default VRF)	
L3 interfaces		2048	
Link Aggregation Groups (LAG)		48, up to 8 ports per LAG	
Quality of Service (QoS)		8 egress queues per port	
Jumbo frames		10240 bytes	

Features and capabilities

Interfaces functions

- HOL blocking protection
- Back Pressure
- Auto MDI/MDIX
- Jumbo frames
- IEEE 802.3X flow control
- Port mirroring (SPAN, RSPAN)

MAC table functions

- Independent mode of learning for each VLAN
- MAC Multicast Support
- Automatic MAC addresses aging
- Static MAC Entries
- MAC Flapping logging

VLAN functions

- Voice VLAN
- IEEE 802.1Q
- Q-in-Q
- Selective Q-in-Q
- GVRP

L2 Multicast functions

- Multicast profiles
- Multicast static groups
- IGMP Snooping v1,2,3
- Port/host based IGMP Snooping fast-leave
- PIM Snooping
- IGMP proxy-report
- Support for IGMP authorization via RADIUS
- MLD Snooping v1,2
- IGMP Querier
- MVR

L2 functions

- STP (Spanning Tree Protocol, IEEE 802.1d)
- RSTP (Rapid Spanning Tree Protocol, IEEE 802.1w)
- MSTP (Multiple Spanning Tree Protocol, IEEE 802.1s)
- STP Multiprocess
- PVSTP+
- RPVSTP+
- Spanning Tree Fast Link option
- STP Root Guard
- STP Loop Guard
- BPDU Filtering
- STP BPDU Guard
- Loopback Detection (LBD) based on VLAN
- ERPS (G.8032v2)
- Flex-link
- Private VLAN, Private VLAN Trunk
- Layer 2 Protocol Tunneling (L2PT)

L3 functions

- Static IPv4 and IPv6 routes
- Dynamic routing protocols: RIPv2, OSPFv2, OSPFv3, IS-IS (IPv4 Unicast), BGP¹ (IPv4 Unicast, IPv4 Multicast, IPv6 Unicast)
- BFD (for BGP, OSPF)
- Address Resolution Protocol (ARP)
- Proxy ARP
- Policy-Based Routing (IPv4)
- VRRP
- Multicast routing protocols: PIM SM, PIM DM, IGMP Proxy, MSDP
- ECMP load balancing
- IP Unnumbered
- GRE
- VRF Lite

Link Aggregation functions

- Static LAG
- Dynamic LAG (LACP)
- LAG Balancing Algorithms
- Multi-Switch Link Aggregation Group (MLAG)

IPv6 functions

- IPv6 Host
- Dual-stack

Service functions

- Virtual Cable Testing (VCT)
- Optical transceiver diagnostic
- Green Ethernet

Security functions

- Protection against unauthorized DHCP servers (DHCP Snooping)
- DHCP option 82
- IP Source Guard
- Dynamic ARP Inspection
- First Hop Security
- sFlow
- MAC-based authentication, Port Security, static MAC entries
- Port-based authentication IEEE 802.1x
- Guest VLAN
- DoS attack prevention
- Traffic segmentation
- DHCP client filtering
- BPDU attack prevention
- NetBIOS/NetBEUI filtering
- PPPoE Intermediate Agent

¹ BGP protocol support is provided under license.

Features and capabilities (continued)

ACL (Access Control List)

- L2-L3-L4 ACL (Access Control List)
- Time-Based ACL
- IPv6 ACL
- ACL based on:
 - Physical port number
 - IEEE 802.1p
 - VLAN ID
 - Ethertype
 - DSCP
 - Protocol type
 - TCP/UDP port number
 - User Defined Bytes

Quality of service (QoS) and rate limiting

- QoS statistics
- Port rate limiting (shaping, policing)
- IEEE 802.1p CoS
- Storm Control for different types of traffic (broadcast, multicast, unknown unicast)
- Bandwidth management
- Scheduling algorithms: Strict Priority (SP)/Weighted Round Robin (WRR)
- Three marking colors
- ACL-based CoS/DSCP mark assignment
- ACL-based VLAN mark assignment
- 802.1p priorities adjustment for Management VLAN
- CoS to DSCP, DSCP to CoS remarking
- 802.1p DSCP mark assignment for IGMP

OAM/CFM

- IEEE 802.3ah Ethernet Link OAM
- IEEE 802.1ag Connectivity Fault Management (CFM)
- IEEE 802.3ah Unidirectional Link Detection

Time synchronization

- SNTP (Simple Network Time Protocol) client
- NTP (Network Time Protocol) client, NTP server, NTP peer

Management functions

- Configuration file download and upload via TFTP/SCP/SFTP/FTP
- Redirecting the output of CLI commands to an arbitrary file on ROM
- SNMP (Simple Network Management Protocol)
- Command line interface (CLI)
- WEB interface
- Syslog
- Ping (IPv4/IPv6)
- Traceroute
- LLDP (802.1ab) + LLDP MED
- Processing traffic management with two 802.1Q headers
- Authorization of entered commands using TACACS+ server
- Access control – privilege levels
- Management interface blocking
- Local authentication
- IP addresses filtering for SNMP
- RADIUS and TACACS+ (Terminal Access Controller Access Control System) clients
- Change of Authorization (CoA)
- Telnet server and client
- SSH server and client
- Remote start of commands via SSH
- SSL
- Macrocommands
- CLI commands logging
- System log
- DHCP autoprovision
- DHCP Relay (Option 82)
- DHCP Option 12
- DHCPv6 Relay, DHCPv6 LDRA (Option 18, 37)
- DHCP server

- PPPoE Circuit ID tag
- Debugging commands
- Rate limit of traffic to CPU
- Password encryption
- Password recovery
- DNS server (Resolver)

Monitoring functions

- Interface statistics
- RMON
- IP SLA
- CPU utilization monitoring per task and traffic type
- RAM monitoring
- Temperature monitoring
- TCAM utilization monitoring

MIB/IETF Standards

- RFC 1065, 1066, 1155, 1156, 2578 MIB Structure
- RFC 1212 Concise MIB Definitions
- RFC 1213 MIB II
- RFC 1215 MIB Traps Convention
- RFC 1493, 4188 Bridge MIB
- RFC 1157, 2571-2576 SNMP MIB
- RFC 1901-1908, 3418, 3636, 1442, 2578 SNMPv2 MIB
- RFC 1271, 1757, 2819 RMON MIB
- RFC 2465 IPv6 MIB
- RFC 2466 ICMPv6 MIB
- RFC 2737 Entity MIB
- RFC 4293 IPv6 SNMP Mgmt Interface MIB
- Private MIB
- RFC 3289 DIFFSERV MIB
- RFC 2021 RMONv2 MIB
- RFC 1398, 1643, 1650, 2358, 2665, 3635 Ether-like MIB
- RFC 2668 802.3 MAU MIB
- RFC 2674, 4363 802.1p MIB
- RFC 2233, 2863 IF MIB
- RFC 2618 RADIUS Authentication Client MIB
- RFC 4022 MIB for TCP
- RFC 4113 MIB for UDP
- RFC 3298 MIB for Diffserv
- RFC 2620 RADIUS Accounting Client MIB
- RFC 2925 Ping & Traceroute MIB
- RFC 768 UDP
- RFC 791 IP
- RFC 792 ICMPv4
- RFC 2463, 4443 ICMPv6
- RFC 4884 Extended ICMP for Multi-Part messages support
- RFC 793 TCP
- RFC 2474, 3260 Definition of the DS field in the IPv4 and IPv6 headers
- RFC 1321, 2284, 2865, 3580, 3748 Extensible Authentication Protocol (EAP)
- RFC 2571, RFC2572, RFC2573, RFC2574 SNMP
- RFC 826 ARP
- RFC 854 Telnet
- IEC 61850

Use case

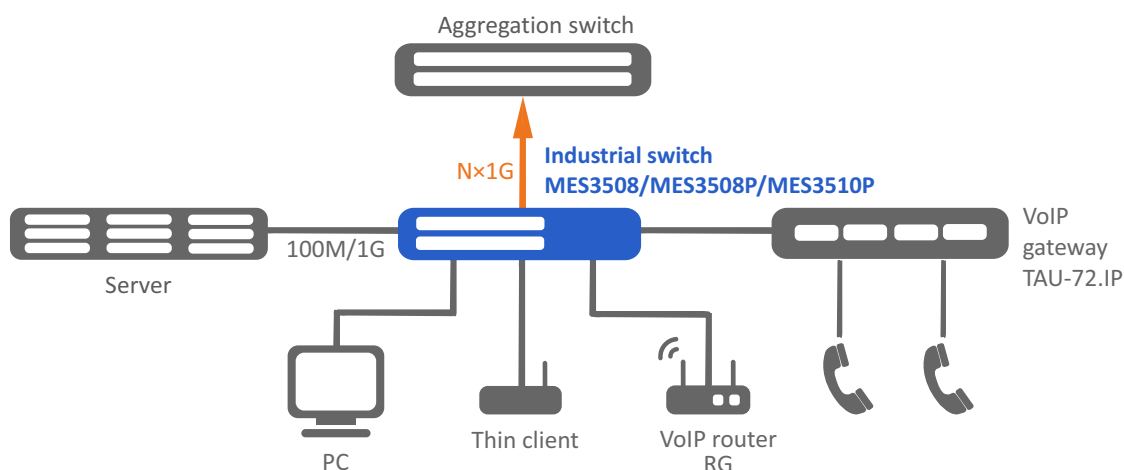

Physical specifications

	MES3508	MES3508P	MES3510P
Physical specifications and environmental parameters			
Power supply	20–75 V DC	with PoE enabled: 45–57 V DC with PoE disabled: 20–57 V DC	
Input current	0.75–0.2 A	with PoE enabled: 5.67–4.47 A with PoE disabled: 0.75–0.26 A	with PoE enabled: 5.78–4.56 A with PoE disabled: 1.0–0.35 A
Maximum power consumption (including PoE)	15 W	260 W	260 W
PoE budget	—	240 W (for 802.3at applications, 54–56 V DC is recommended)	240 W (for 802.3at applications, 54–56 V DC is recommended)
Heat dissipation	15 W	20 W	20 W
Hardware support for Dying Gasp	no	no	no
Reverse polarity protection	yes		
Signal relay	one signal relay output: 1 A, 24 V DC		
Operating temperature	from -40 to +70 °C		
Storage temperature	from -50 to +85 °C		
Operating humidity	from 5 to 95 % (without condensation)		
Cooling	passive cooling		
Case	metal, IP30		
Form factor	DIN rail for wall mounting		
Dimensions (W × H × D)	85 × 152 × 115 mm	85 × 152 × 115 mm	85 × 175 × 115 mm
Weight	1.36 kg	1.40 kg	1.74 kg

Physical specifications (continued)

Standards and certificates	
Security	UL 508
Electromagnetic compatibility	EN 55022 Class A EN 61000-4-2 (ESD) Level 3 EN 61000-4-3 (RS) Level 3 EN 61000-4-4 (EFT) Level 3 EN 61000-4-5 (Surge) Level 3 EN 61000-4-6 (CS) Level 3 EN 61000-4-8
Application within power engineering facilities	IEC 61850-3 IEEE 1613
Shock	IEC 60068-2-27
Free fall	IEC 60068-2-32
External mechanical stress	0.5–55 Hz, 1g, 3g single strikes

Ordering information

Name	Description
MES3508	MES3508 Ethernet switch, 8 ports of 10/100/1000BASE-T, 2 Combo ports of 10/100/1000BASE-T/100BASE-FX/1000BASE-X, L3, 20–75 V DC
MES3508P	MES3508P Ethernet switch, 8 ports of 10/100/1000BASE-T (PoE/PoE+), 2 Combo ports of 10/100/1000BASE-T/100BASE-FX/1000BASE-X, L3, 45–57 V DC with PoE (20–57 V DC without PoE)
MES3510P	MES3510P Ethernet switch, 8 ports of 10/100/1000BASE-T (PoE/PoE+), 4 ports of 100BASE-FX/1000BASE-X, (SFP), L3, 45–57 V DC with PoE (20–57 V DC without PoE)

Related products

DRS-270-56	DRS-270-56 power module, 110–240 V AC, 270 W
------------	--

Related software

ECCM-MES3508	ECCM-MES3508 option of Eltex ECCM control system to manage and monitor Eltex network elements: 1 network element MES3508
ECCM-MES3508P	ECCM-MES3508P option of Eltex ECCM control system to manage and monitor Eltex network elements: 1 network element MES3508P
ECCM-MES3510P	ECCM-MES3510P option of Eltex ECCM control system to manage and monitor Eltex network elements: 1 network element MES3510P

Contact us

About Eltex



+7 (383) 274 10 01
+7 (383) 274 48 48



eltex@eltex.ru



eltex-co.com

Eltex Enterprise is a leading Russian developer and manufacturer of communication equipment with 30 years of history. Complete solutions and their seamless integrability into the Customer's infrastructure are the priority growth areas of the company.