

- Battery-operated
- Operation in smart home scenarios
- Easy installation
- Support for Matter over Thread protocol



ST-AIR-HT01 is a temperature and humidity sensor that operates under Matter over Thread technology.

The device is battery-operated, so it can be installed in the location of choice without the need for wiring.

Eltex smart home

ST-AIR-HT01 is part of the Eltex smart home ecosystem based on ELIS (Eltex IoT System). The user manages smart devices and sensors via the smart home hub using iOS or Android mobile device with the Eltex Home app installed. It can be downloaded from the AppStore and GooglePlay or via the QR code below. The application is also available in the RuStore and Huawei AppGallery.



ST-AIR-HT01 is part of the Eltex smart home “Control” service. The sensors included in this service are used to create a comfortable home environment and monitor temperature and humidity levels. They can operate separately or as group depending on the needs of the user. To connect the sensor to the network, you need an Eltex SH-130 smart home hub that supports Matter over Thread technology.

Technical features

General parameters	
Power	2 × AAA batteries or 5 V Type-C adapter
Signal frequency	2.4 GHz
Guaranteed distance to hub	120 m (in the absence of obstacles)
Ingress protection	IP20
Indoor relative humidity measurement range	from 0 to 95 %
Indoor temperature measurement range	from +5 to +45 °C
Dimensions (D × H)	70 × 31 mm
Weight (including batteries)	no more than 57.5 g
Operating humidity at 40 °C	up to 93 % non-condensing
Maximum RF strength	+14 dBm

Use case

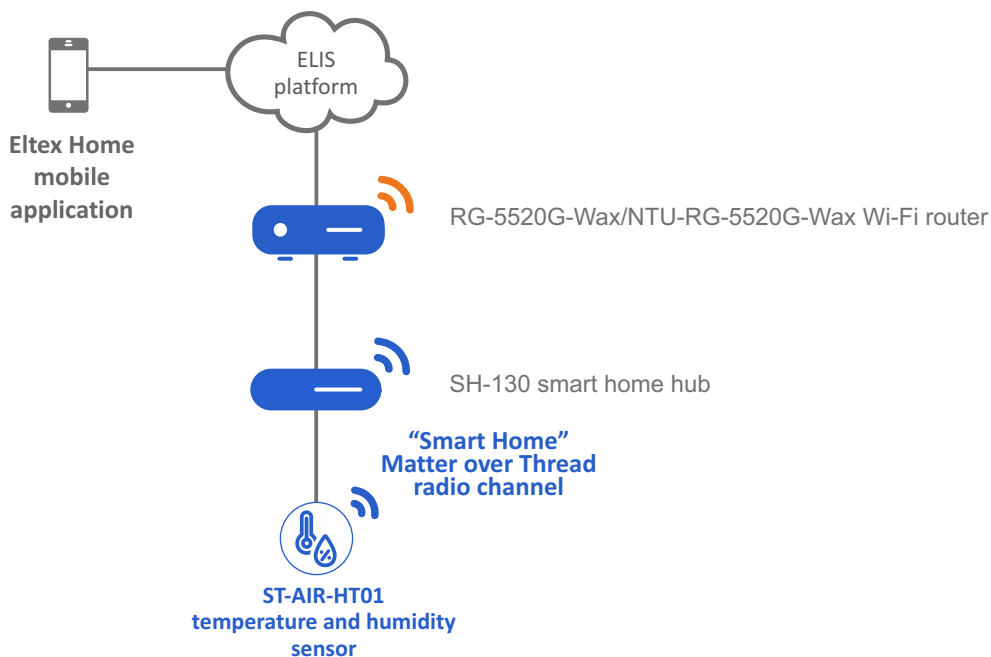

Scenarios

With the Eltex Home mobile application, it is possible to create chains of conditions for sensors operating under Matter over Thread and smart Wi-Fi devices to work together. For example, the ST-AIR-HT01 temperature and humidity sensor can be used in the following scenarios:

1. Notifying the user when humidity and temperature parameters deviate from threshold values set in the application



2. The sensor can work together with a smart socket, for example to configure heating/ventilation/humidification scenarios

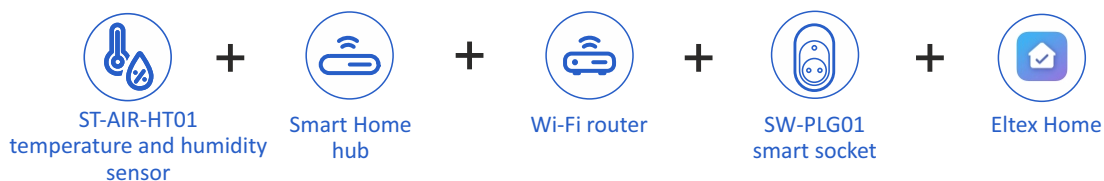

3. Automatic shutdown of equipment based on a signal from the magnetic contact door/window sensor



Ordering information

Name	Description
ST-AIR-HT01	ST-AIR-HT01 Matter over Thread temperature and humidity sensor
Licenses	
Eltex ELIS-1	Eltex ELIS option, package for 1 device, 1 year
Eltex ELIS-100	Eltex ELIS option, package for 100 devices, 1 year
Eltex ELIS-500	Eltex ELIS option, package for 500 devices, 1 year
Eltex ELIS-1000	Eltex ELIS option, package for 1000 devices, 1 year
Eltex ELIS-1500	Eltex ELIS option, package for 1500 devices, 1 year

Contact us

About Eltex



+7 (383) 274 10 01
+7 (383) 274 48 48



eltex@eltex.ru



eltex-co.com

Eltex Enterprise is a leading Russian developer and manufacturer of communication equipment with 30 years of history. Complete solutions and their seamless integrability into the Customer's infrastructure are the priority growth areas of the company.